

crystal_facet_uml user documentation

COLLABORATORS

	<i>TITLE :</i> crystal_facet_uml user documentation		
<i>ACTION</i>	<i>NAME</i>	<i>DATE</i>	<i>SIGNATURE</i>
WRITTEN BY	Andreas Warnke	2018-12-02	

REVISION HISTORY

NUMBER	DATE	DESCRIPTION	NAME

Contents

1	Introduction	1
1.1	Goal	1
1.2	Features	1
1.3	Usage Overview	2
2	Example Diagrams	2
2.1	Feature List	2
2.2	Example UML Behavioral Views	4
2.3	Example UML Static Views	7
2.4	Example SysML Views	9
2.5	Other Examples	10
3	GUI	10
3.1	Window Area Overview	10
3.2	Tool Bar	11
3.2.1	Create/Use DB	11
3.2.2	Export	12
3.2.3	New Window	12
3.2.4	Navigate	12
3.2.5	Edit	12
3.2.6	Create	12
3.2.7	Cut	12
3.2.8	Copy	13
3.2.9	Paste	13
3.2.10	Delete	13
3.2.11	Instantiate	13
3.2.12	Highlight	13
3.2.13	Reset Selection	13
3.2.14	Undo	13
3.2.15	Redo	14
3.2.16	About	14
3.3	Drawing Area	14
3.3.1	Navigate	14
3.3.2	Edit	14
3.3.3	Create	15
3.4	Element Configuration Area	15
3.4.1	Maximum stringlengths	15

3.4.2	Commit	16
3.5	Notification Bar	16
3.5.1	Information	16
3.5.2	Warning	16
3.5.3	Error	16
4	Modelling Guidelines	17
4.1	crystal_facet_uml Hints	17
4.1.1	Tree Structure	17
4.1.2	Focus	17
4.1.3	Namespaces	17
4.1.4	Attic/Storage room	17
4.2	General Hints on Architecture Documentation	18
4.2.1	Problem vs. Solution	18
4.2.2	Names	18
4.2.3	Description	18
4.2.4	Precise sentences	18
4.2.5	Distinguish similar things	18
A	Download Information	18
A.1	Download Links	18
A.2	License	18

1 Introduction



crystal_facet_uml is an application to support software architects.

1.1 Goal



crystal_facet_uml creates a set of uml diagrams.

It ensures consistency of uml elements: Their names and their relationships are in sync in all diagrams.

crystal_facet_uml exports diagrams in various vector and pixel-based image formats.

1.2 Features



crystal_facet_uml provides a graphical user interface to

- create diagrams
(use-case, deployment, component, composite-structure, package, class, activity, state, timing, communication, sequence)
- create uml elements
(actor, system-boundary, use-case, node, component, part, interface, package, class, activity, state, object, artifact, comment, requirement)
- move, modify and delete uml elements
- create, modify and delete relationships
(dependency, association, aggregation, composition, generalization, realization, contains, sync-call, return-call, async-message, communication-path, control-flow, object-flow, deployment, manifest, include, extend)
- create, modify and delete features
(port, field, operation)
- cut, copy, paste uml elements between diagrams
- undo and redo are supported
- multiple windows can show different or same parts of the uml model

Diagrams are layouted part-automatically:

- The user chooses the relative location of uml elements towards others
- crystal_facet_uml selects the exact locations of uml elements
- The user controls the positions of messages/transitions in sequence and timing diagrams

- crystal_facet_uml auto-lays out relationships in other diagrams

crystal_facet_uml manages a meta model:

- Diagrams are organized as a tree, similar to a book's table-of-contents
- Uml elements exist only once even if shown in many diagrams
- Relationships and features are consistent between all diagrams
- Diagram-local messages/transitions are supported in scenario-based diagrams (sequence, communication, timing)

crystal_facet_uml exports diagrams as

- vector graphics (pdf, ps, svg)
- pixel graphics (png)
- textual representation (utf-8)

crystal_facet_uml can also be started from command line to check and repair database files.

1.3 Usage Overview



crystal_facet_uml can be started in graphical mode (see Section 3) or from command line (for help run **crystal_facet_uml -h**).

2 Example Diagrams

This sections presents the features of crystal_facet_uml.

2.1 Feature List

This section lists what kind of elements crystal_facet_uml can draw in diagrams.

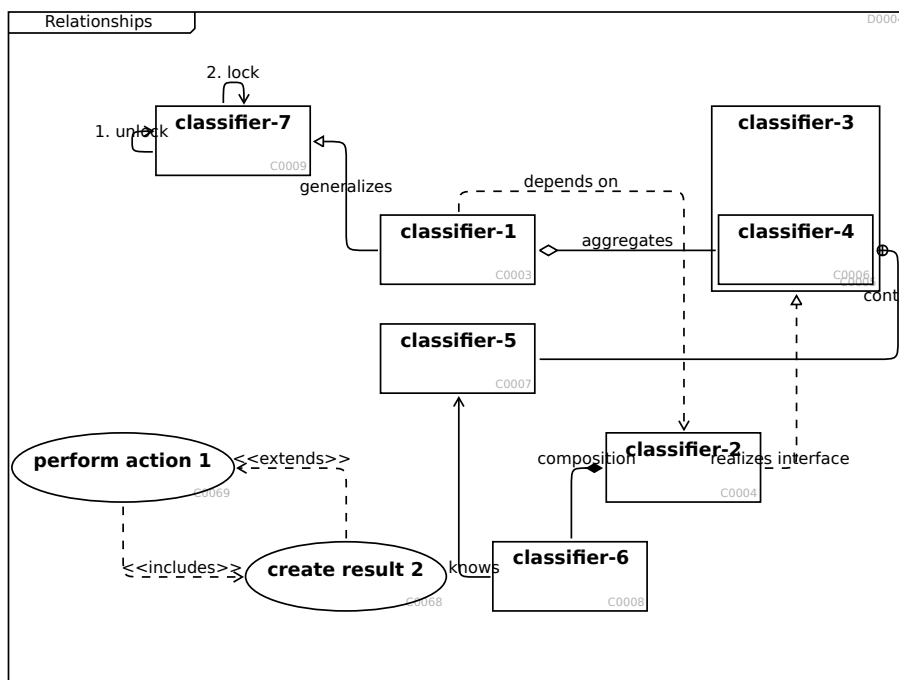
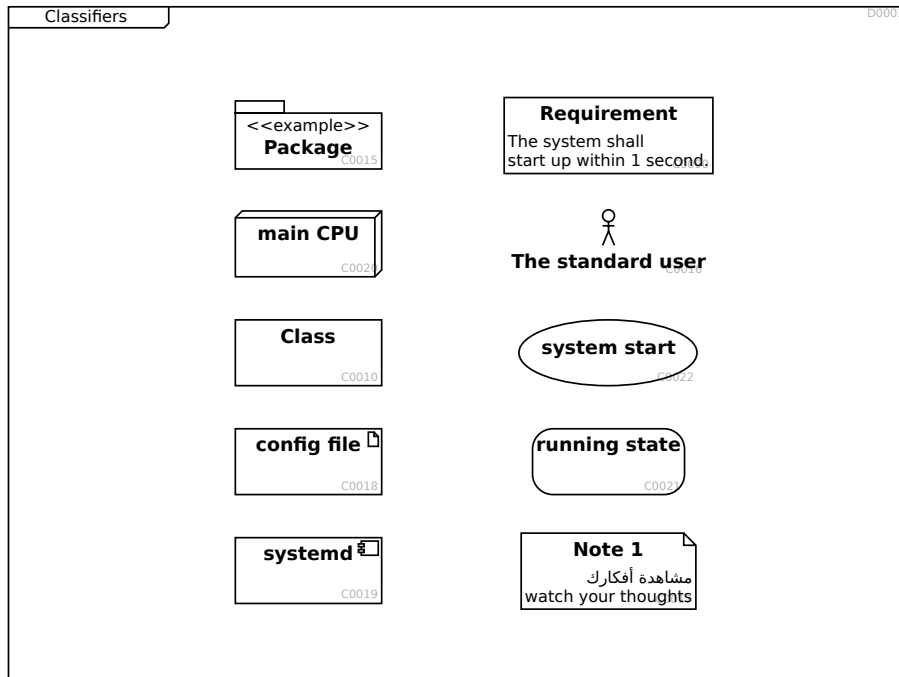

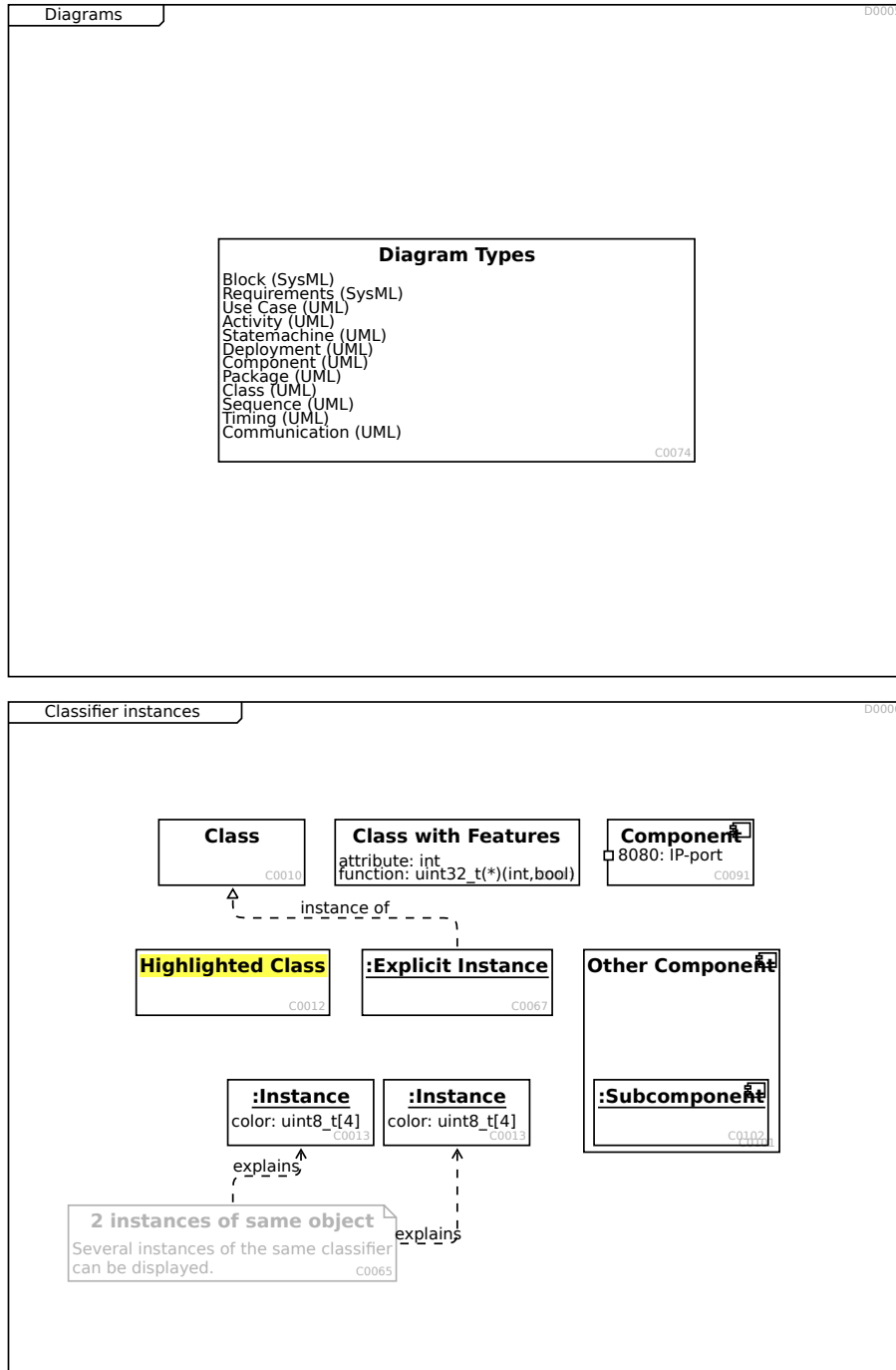

2.2 Example UML Behavioral Views

This section lists what kind of elements crystal_facet_uml can draw in diagrams.

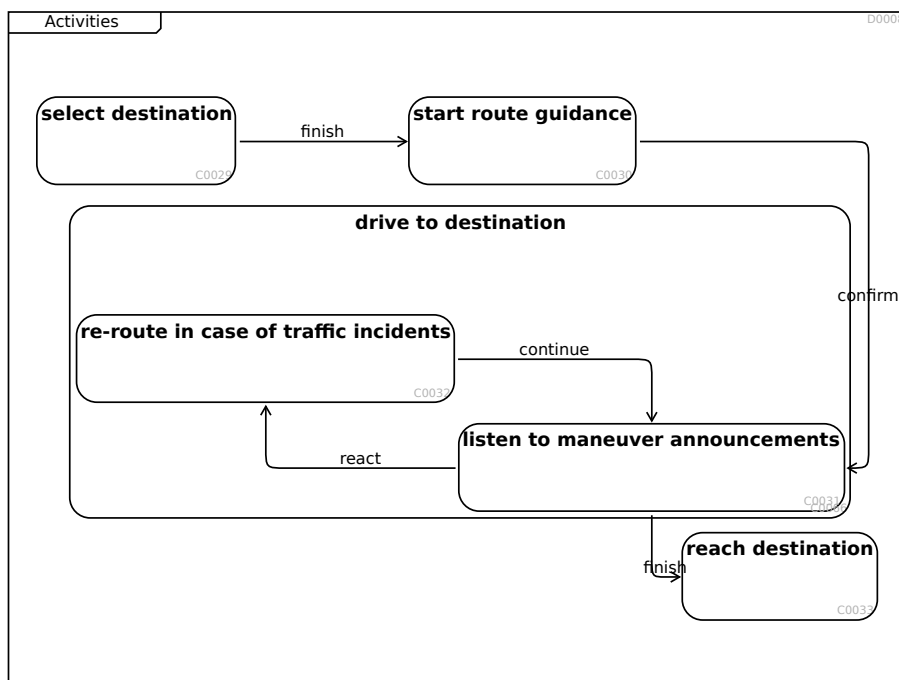
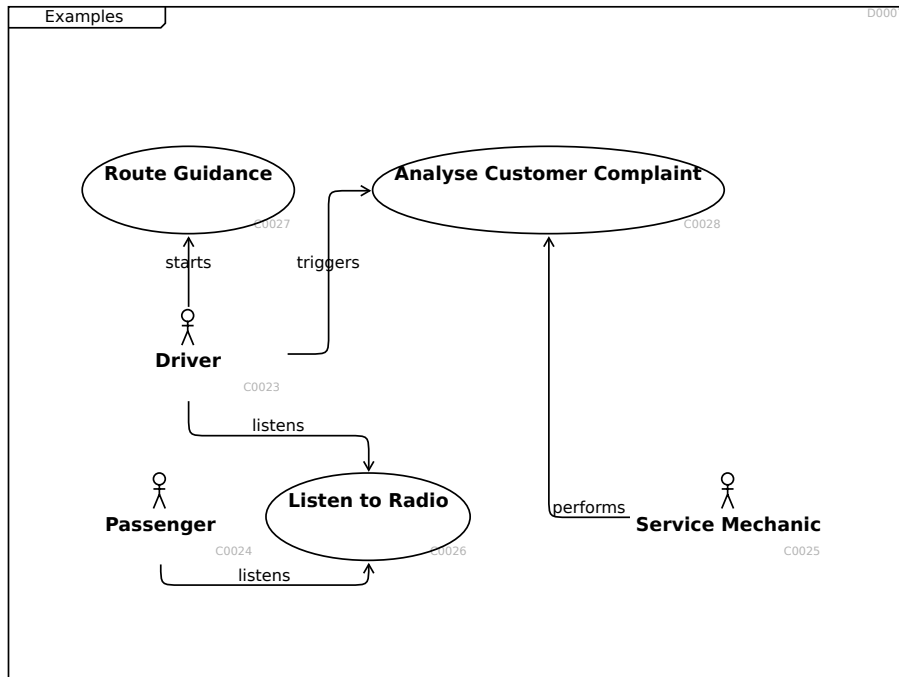

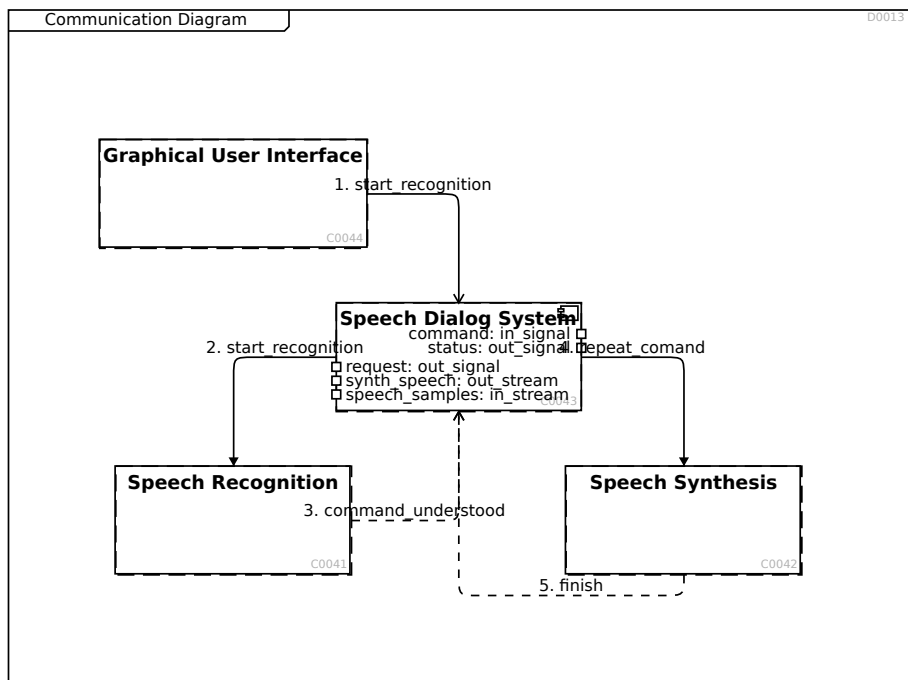
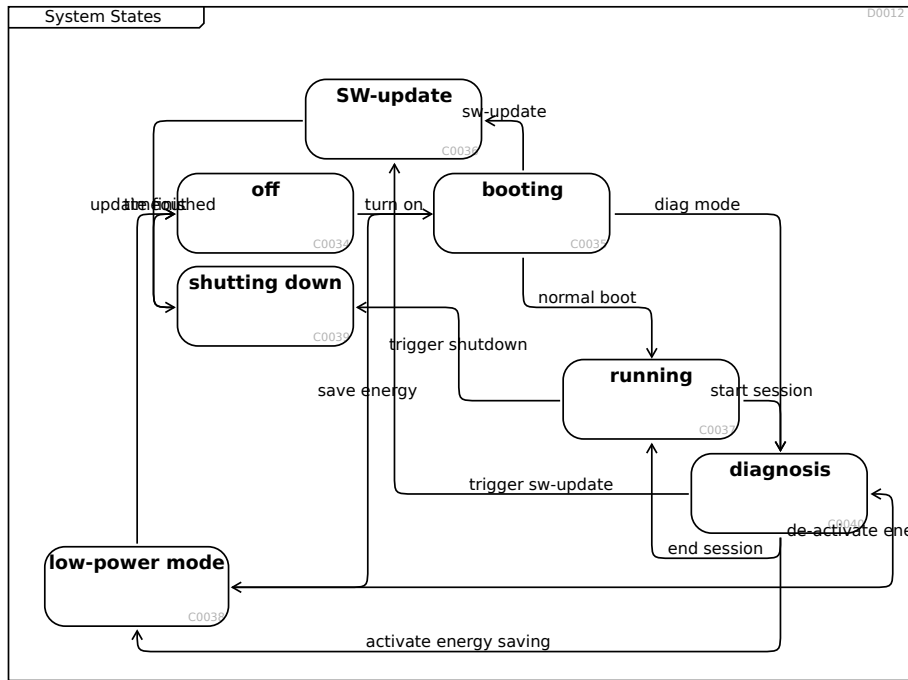

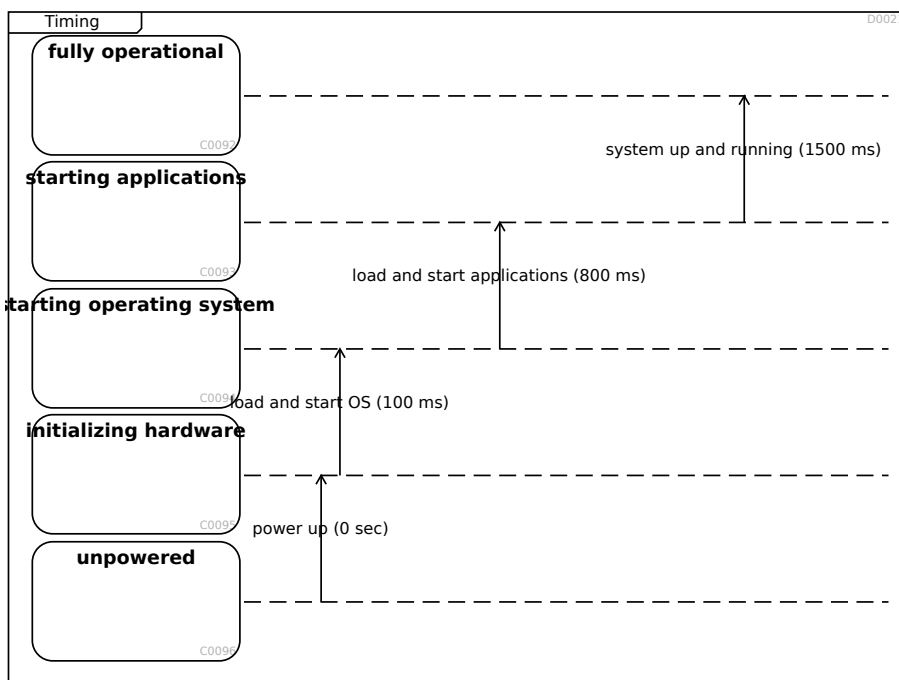
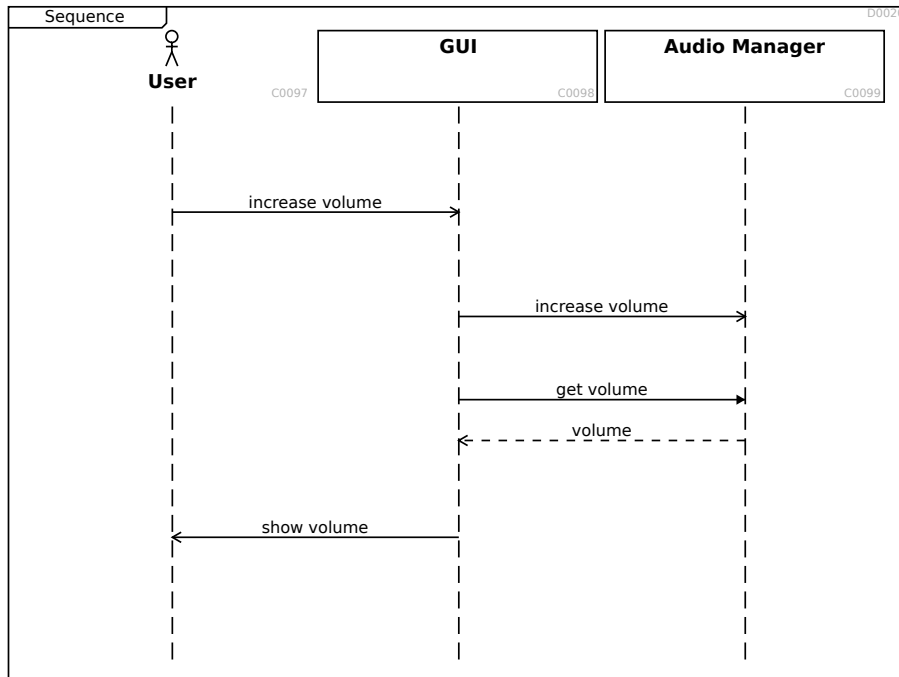

2.3 Example UML Static Views

This section lists what kind of elements crystal_facet_uml can draw in diagrams.

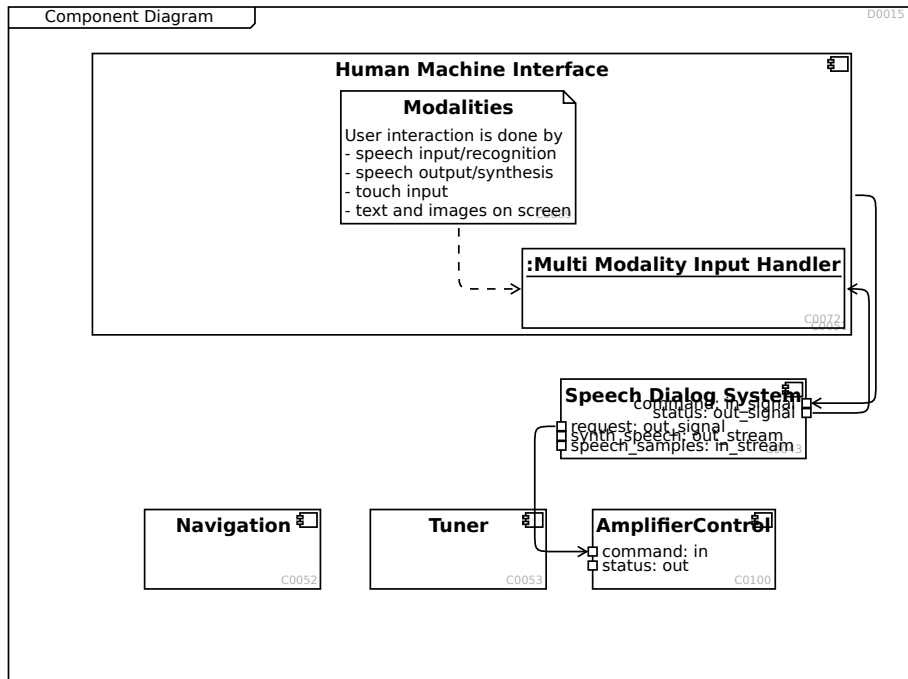
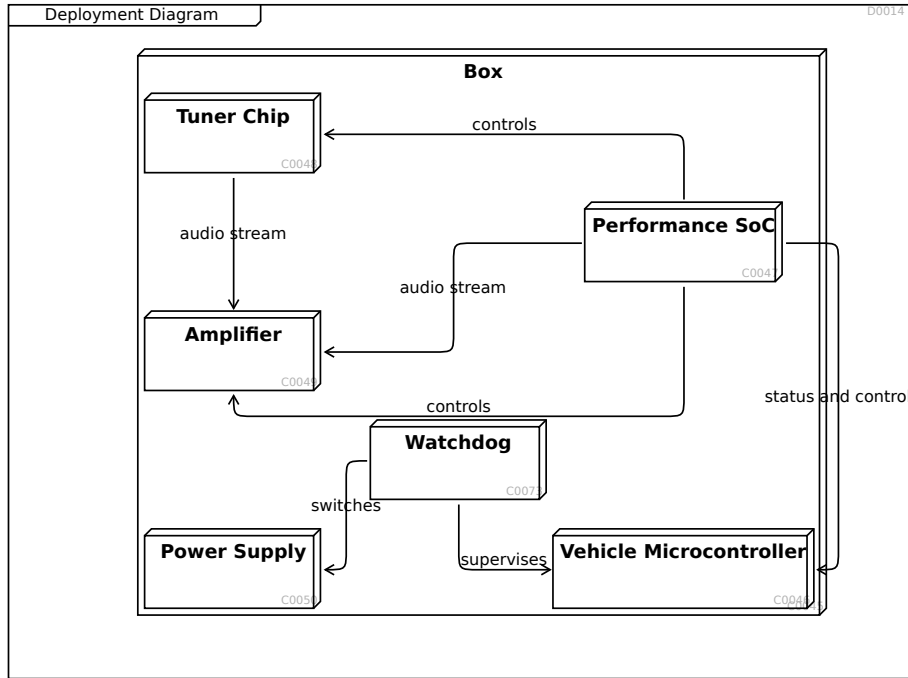

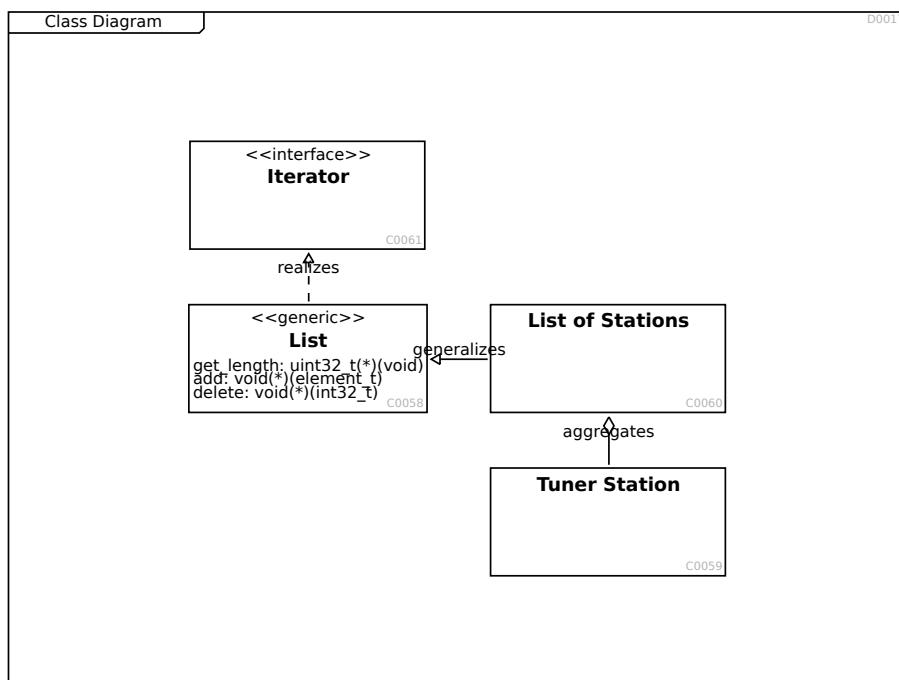
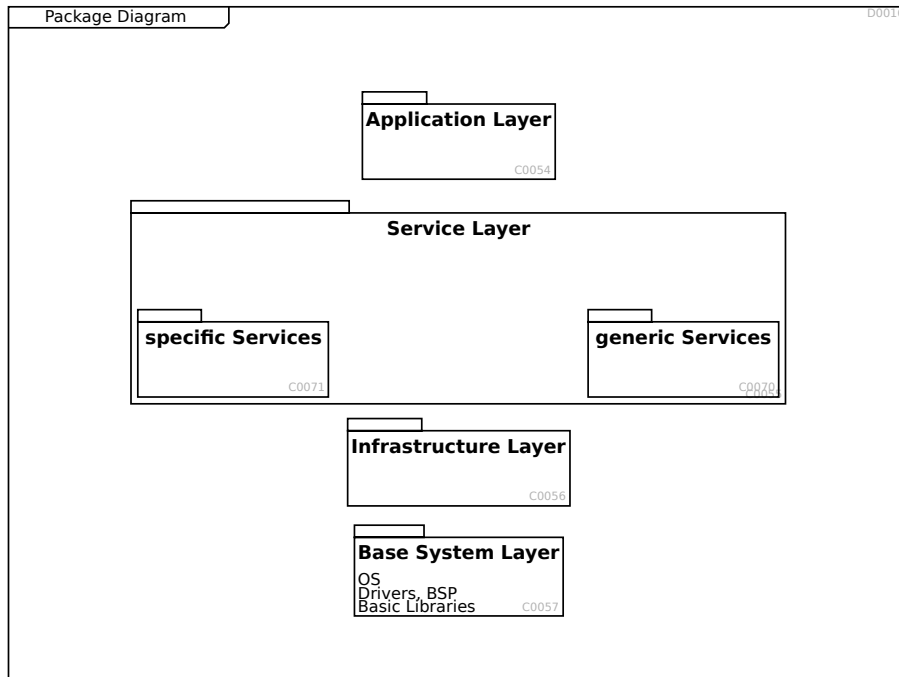

2.4 Example SysML Views

This section lists what kind of elements crystal_facet_uml can draw in diagrams.

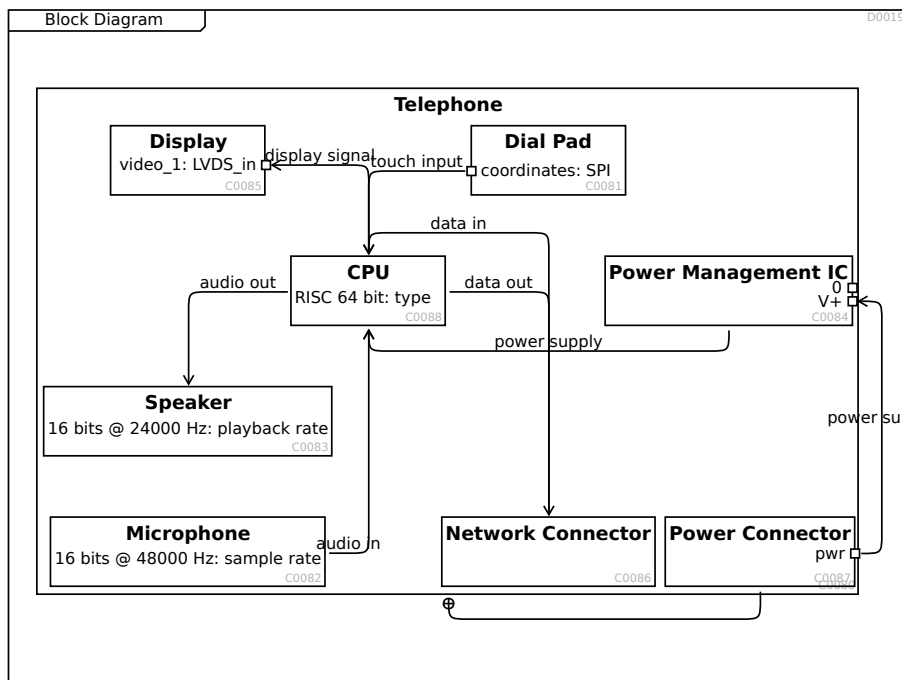
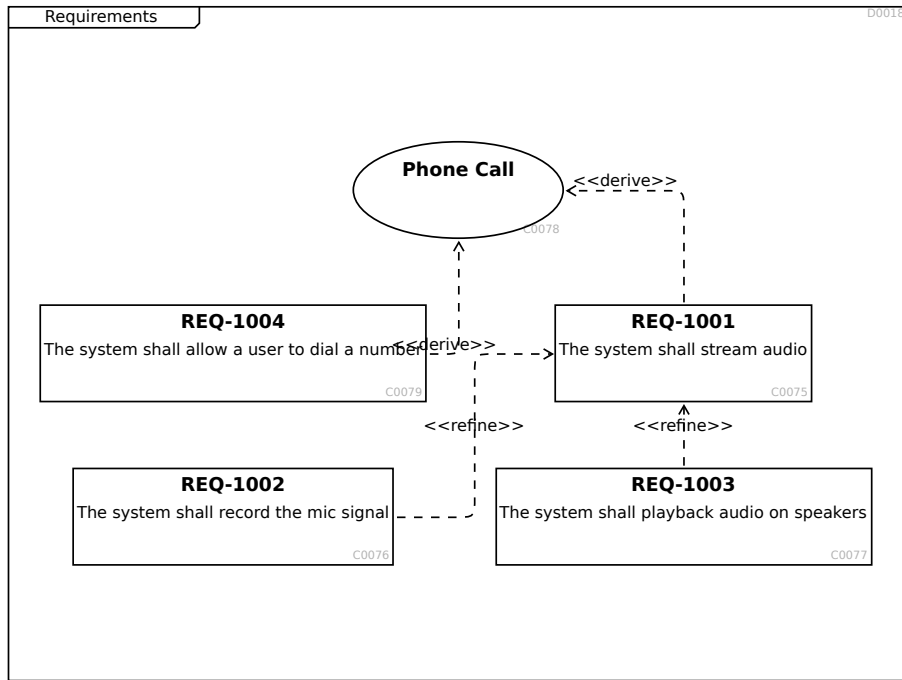

2.5 Other Examples

See https://github.com/awarnke/crystal_facet_uml/blob/master/example_diagrams/quality.pdf to get another view on how to use crystal_facet_uml.

3 GUI

3.1 Window Area Overview

If started in graphical mode, crystal_facet_uml shows a window with

- toolbar on top,
- drawing area in the center,
- element configuration widgets to the right and
- an optional notification bar at the bottom.

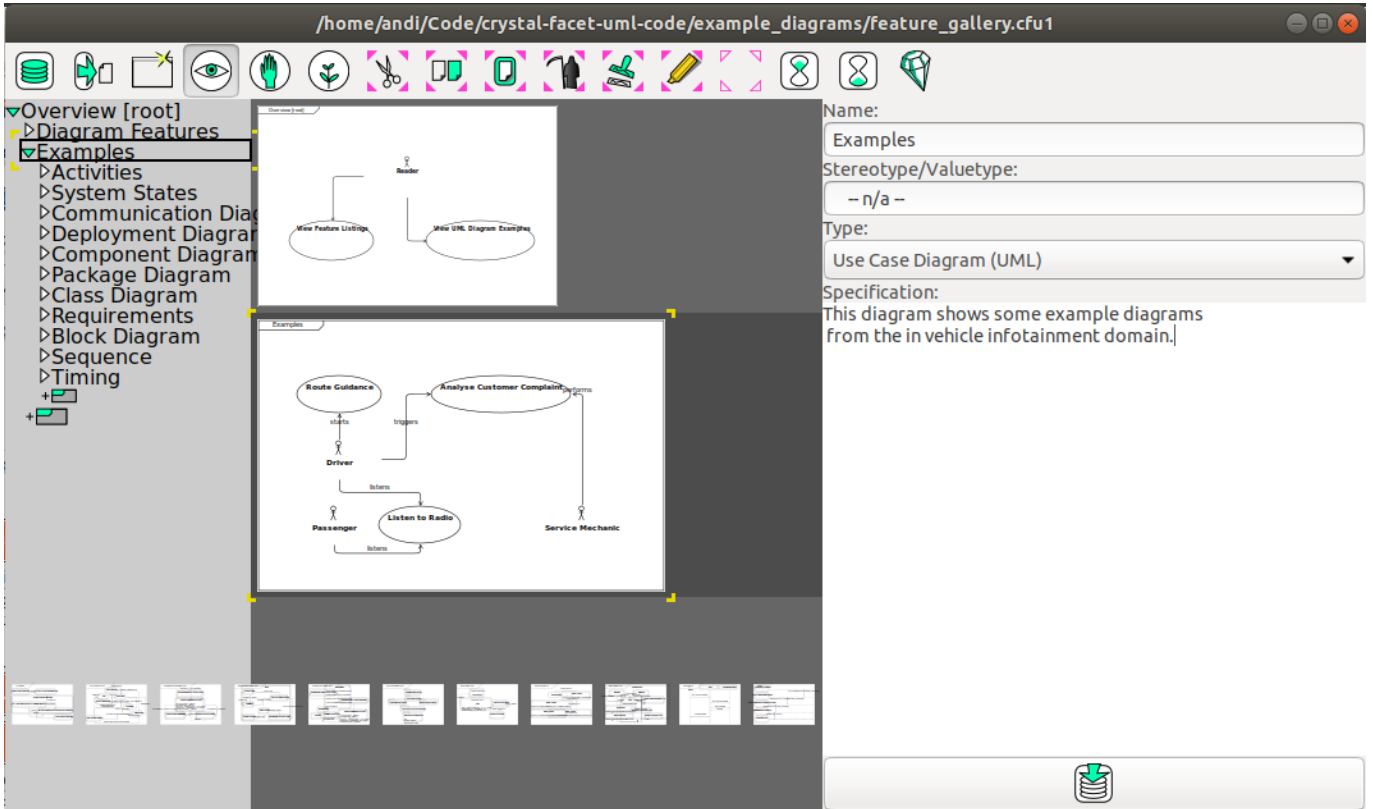

3.2 Tool Bar

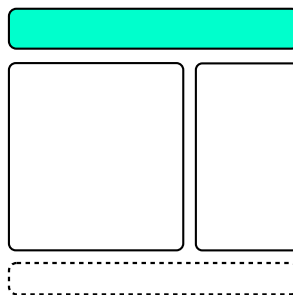

3.2.1 Create/Use DB



- Opens an existing database file or creates a new database file

3.2.2 Export



- Exports all diagrams to the selected folder (supported formats are txt, png, pdf, ps and svg)

3.2.3 New Window



- Opens another window on the same database.

This option allows you to work reliably with multiple windows on the same database.

3.2.4 Navigate



- Navigate to parent or child diagrams
- Create a new diagram (see Section [3.3.1](#))

3.2.5 Edit



- Modify elements in the diagram (see Section [3.3.2](#))

3.2.6 Create



- Create elements in the diagram (see Section [3.3.3](#))

3.2.7 Cut



- Cut all pink-cornered elements to the clipboard (features of classifiers are cut independantly of their corner-colors)

3.2.8 Copy



- Copy all pink-cornered elements to the clipboard (features of classifiers are copied independantly of their corner-colors)

3.2.9 Paste



- Pastes diagrams and classifiers from the clipboard to the uml model. (Relationships are not pasted) If id and name are identical to an existing element, an instance of the existing element is pasted to the diagram. Otherwise a new element is created.

3.2.10 Delete



- Deletes all pink-cornered elements. This operation may fail if a marked diagram contains unmarked elements.

3.2.11 Instantiate



- Toggles the pink-cornered classifiers between classes and instances. (Does not work for relationships and features)

3.2.12 Highlight



- Toggles the pink-cornered classifiers between yellow-marked, greyed-out and normal. (Does not work for relationships and features)

3.2.13 Reset Selection



- Resets the pink-cornered selection

3.2.14 Undo



- Un-does the last operation (Opening a database and exporting files cannot be undone)
-

3.2.15 Redo



- Re-does the last un-done operation

3.2.16 About



- Shows version, license and copyrights

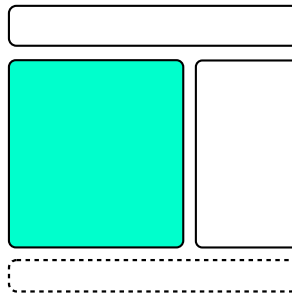

3.3 Drawing Area



Diagrams are layouted automatically. You can influence the locations of classifiers only. When adding too many classifiers or relations, auto layouting may not achieve the expected results. In many cases, splitting the diagram into two or more diagrams solves the layouting issues and at the same time improves understandability by focusing on one aspect/topic per diagram.

3.3.1 Navigate



- To navigate to parent, sibling or children diagrams, click on the diagram.
- To create a new diagram, click on the  icon, or the smaller  icon for a new child-diagram.
- To restructure the diagram tree, drag a diagram name to the new location.

3.3.2 Edit



- To select the diagram or a classifier or a feature or a relationship with yellow corners, click on this object.
- To mark an element with pink corners, click on these objects twice.
- To move classifiers within the diagram, 1.) press, 2.) drag and 3.) release the mouse button.

3.3.3 Create

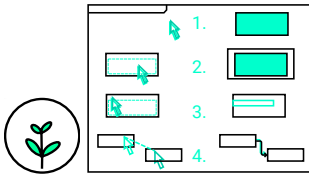

1. To create a classifier, click at an empty space in the diagram.
2. To create a child classifier, click into the white space of a classifier. (Alternatively, create a classifier and a containment relationship.)
3. To create a feature, click onto a classifier (name or border).
4. To create a relationship, press on the source classifier and drag it to the destination classifier.

3.4 Element Configuration Area

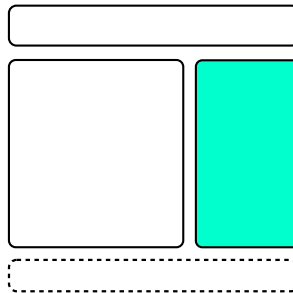

Edit the properties of the yellow-cornered object.

- name of the focused object
- stereotype/valuetype of the focused object (deactivated depending on object-type)
- type of the focused object
- description of the focused object

3.4.1 Maximum stringlengths

All strings (names, descriptions, stereotypes) have a maximum length. Ascii characters require one, most other characters two bytes. Current sizes in bytes are: Classifiers:

- `DATA_CLASSIFIER_MAX_NAME_LENGTH = 47,`
- `DATA_CLASSIFIER_MAX_STEREOTYPE_LENGTH = 47,`
- `DATA_CLASSIFIER_MAX_DESCRIPTION_LENGTH = 4095,`

Features:

- `DATA_FEATURE_MAX_KEY_LENGTH = 47, (name)`
- `DATA_FEATURE_MAX_VALUE_LENGTH = 255, (type)`
- `DATA_FEATURE_MAX_DESCRIPTION_LENGTH = 1023,`

Relationships:

- DATA_RELATIONSHIP_MAX_NAME_LENGTH = 47,
- DATA_RELATIONSHIP_MAX_DESCRIPTION_LENGTH = 1023,

Diagrams:

- DATA_DIAGRAM_MAX_NAME_LENGTH = 47,
- DATA_DIAGRAM_MAX_DESCRIPTION_LENGTH = 8191,

3.4.2 Commit



- Stores the latest changes to the database immediately. This feature is optional, it is not necessary to explicitly save the file.

3.5 Notification Bar

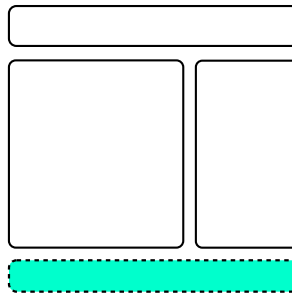

3.5.1 Information



- Informs on success of an operation, e.g. an export

3.5.2 Warning



- Informs on a possible problem

3.5.3 Error



- Informs on an error
-

4 Modelling Guidelines

This page lists remarks on creating a software architecture and design document in general and it lists hints on getting along with the tool `crystal_facet_uml`. As all tools, this program has its strengths and weaknesses. This page helps in making use of the strengths.

4.1 `crystal_facet_uml` Hints

4.1.1 Tree Structure

Diagrams are organized as a tree. Start the root of the tree explaining the document structure. At the second level of the tree, list the main areas to be shown, for example based on the arc42 template <https://arc42.org/overview/> :

- Introduction and Goals
- Constraints
- Context and Scope (show the system boundary, what is outside, what use-cases exist)
- Solution Strategy
- Building Block View,
- Runtime View,
- Deployment View,
- Crosscutting Concepts,
- Architectural Decisions (show alternatives, give a rationale),
- Quality Requirements
- Risks and Technical Debt
- Glossary (table showing Context, Term and Description)

4.1.2 Focus

Put only few elements into each diagram. This increases understandability of the main purpose of the diagram. Put further aspects of a topic into a separate diagram. Do not hesitate to copy an element from one diagram to the next. This is what `crystal_facet_uml` is good at: it keeps the model in sync.

4.1.3 Namespaces

Put a prefix to all your elements denoting its namespace. You can then distinguish a `GLOBAL_START_STATE` from an `AUDIO_START_STATE`. Or `global::start` from `audio::start`.

4.1.4 Attic/Storage room

If you are not sure if you really want to delete elements, 1) copy them to an attic-diagram and then 2) delete them from the original diagram.

4.2 General Hints on Architecture Documentation

4.2.1 Problem vs. Solution

Distinguish things that are

- given constraints (problem space),
- decisions, chosen and rejected alternatives and
- the designed solution

4.2.2 Names

Names of things are crucial: If the reader gets a wrong understanding by the name of an element, a hundred correct sentences of describing text cannot set this straight again.

4.2.3 Description

Every design element needs a description, maybe a list of responsibilities: What shall this element do, what is it for? Names alone cannot explain a system part.

4.2.4 Precise sentences

Be precise: Write in active form, e.g. The persistence component shall store and retrieve binary data records indentified by string-based keys.

4.2.5 Distinguish similar things

Things that are similar but not the same shall be different entities when modelling. E.g. The process in which an example application runs may be different from the storage location and may be different from the software-component. These are three things: Example_App_Process (Type: Node), Example_App_ObjectFile (Type:Artifact) and Example_App_SWComponent (Type:Component).

A Download Information

A.1 Download Links

Find the latest version at:

- <https://sourceforge.net/projects/crystal-facet-uml/>
- https://github.com/awarnke/crystal_facet_uml
- https://build.opensuse.org/package/show/home:awarnke/crystal_facet_uml

User documentation is available here:

- http://www.andreaswarnke.de/crystal_facet_uml/crystal_facet_uml_user_documentation.pdf
- https://github.com/awarnke/crystal_facet_uml/blob/master/user_doc/crystal_facet_uml_user_documentation.pdf

A.2 License

License of crystal_facet_uml is Apache-2.0. crystal_facet_uml contains sqlite which is Public Domain. Unit tests are based on embunit (MIT/X Consortium License). (c) 2016-2019 Andreas Warnke; Email-contact: cfu-at-andreaswarnke-dot-de
